



Prototypes

Your partner for precision metal fabricated assemblies

In the process of developing new or improving existing products, your engineering team needs capable partners that are integral to your team. Delivering results in a fast-paced schedule is the key to the success of your project. Harvey Vogel is the ideal partner to become an extension of your team as we can deliver accurate prototypes in as little as **24 to 48 hours**.



Supporting Your Engineering

Harvey Vogel will work closely with your team through the design phase to provide components that meet the most exacting form, fit, and function requirements. Our experience will support a Value Analysis/Value Engineering (VAVE) process that balances performance and cost. The payback to you through this process will be recognized through your product launch and production.

Prototype Capabilities

Our customers benefit from our experience as well as the tools that we have in our tool box. Utilizing multiple CAD platforms on the front-end, we are able to easily work with your designs to help establish a process.

- Laser
- Water Jet
- Turret
- Press Brake
- Assembly
- Welding
- Powder Coating



Prototypes

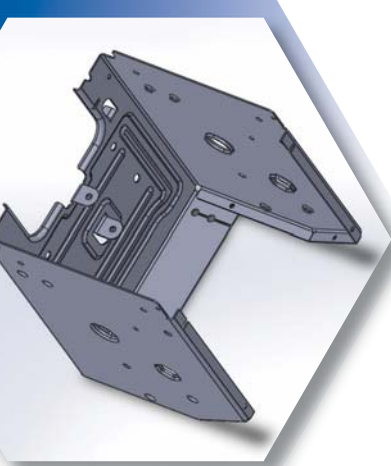

Case Study 1 Gear Case

Our customer was in process of a complete redesign of their power equipment product line. They were on an aggressive timetable and needed to prototype most of the new designs to prove them out. Our engineering team played an integral role in the VAVE process to ensure that the case could be manufactured cost effectively. The size of this part is 14" x 11" x 11".

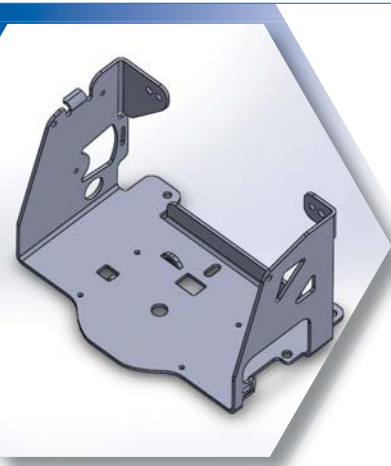

Case Study 2 Rotating Base

Our customer needed a new design for a rotating base for an existing product. The initial parts were completed in three days to support required product testing. The testing process identified some issues with the existing design and the part was redesigned. Harvey Vogel made new parts in an equally short timeframe to support additional testing and acceptance to support the product launch. The size of this part is 10" x 6" x 6".

All of your metal stamping and assembly needs from one source



HARVEY VOGEL MANUFACTURING CO.

Quality Metal Stampings and Fabrications from Prototype through Volume Production.

- 2 facilities totalling 203,000 square feet
- Over 200 punch presses (ranging from 10 to 400 tons) to produce stampings from one millimeter to 72" x 36"
- Short run, medium run and progressive stampings
- Fabrication, laser, machining and waterjet cutting
- Stamp all material types (steel, stainless steel, aluminum, yellow metals)
- Powder coating and mechanical assembly
- Just in time, kanban, 3rd party warehouse and vendor managed inventory programs available
- Ship worldwide
- AS9100, ISO 9001 and ISO 14001 certified



**"Your Complete Metal
Service Manufacturer"**

HARVEY VOGEL MANUFACTURING CO.
425 Weir Drive • Woodbury, MN 55125-1200
(651) 739-7373 • FAX (651) 739-8666

www.harveyvogel.com



Harvey Vogel is an AS9100, ISO 9001 and 14001 Certified Company